

# CD4051B-Q1, CD4052B-Q1, CD4053B-Q1 CMOS ANALOG MULTIPLEXERS/DEMULTIPLEXERS WITH LOGIC-LEVEL CONVERSION

SCHS354A – AUGUST 2004 – REVISED JANUARY 2008

## Features

- Qualified for Automotive Applications
- Wide Range of Digital and Analog Signal Levels
  - Digital: 3 V to 20 V
  - Analog:  $\leq 20 V_{P-P}$
- Low ON Resistance, 125  $\Omega$  (Typ) Over 15  $V_{P-P}$  Signal Input Range for  $V_{DD} - V_{EE} = 18 V$
- High OFF Resistance, Channel Leakage of  $\pm 100 pA$  (Typ) at  $V_{DD} - V_{EE} = 18 V$
- Logic-Level Conversion for Digital Addressing Signals of 3 V to 20 V ( $V_{DD} - V_{SS} = 3 V$  to 20 V) to Switch Analog Signals to 20  $V_{P-P}$  ( $V_{DD} - V_{EE} = 20 V$ )
- Matched Switching Characteristics,  $r_{on} = 5 \Omega$  (Typ) for  $V_{DD} - V_{EE} = 15 V$
- Very Low Quiescent Power Dissipation Under All Digital-Control Input and Supply Conditions, 0.2  $\mu W$  (Typ) at  $V_{DD} - V_{SS} = V_{DD} - V_{EE} = 10 V$
- Binary Address Decoding on Chip
- 5-V, 10-V, and 15-V Parametric Ratings
- 100% Tested for Quiescent Current at 20 V
- Maximum Input Current of 1  $\mu A$  at 18 V Over Full Package Temperature Range, 100 nA at 18 V and 25°C
- Break-Before-Make Switching Eliminates Channel Overlap

## Applications

- Analog and Digital Multiplexing and Demultiplexing
- Analog-to-Digital (A/D) and Digital-to-Analog (D/A) Conversion
- Signal Gating

## description/ordering information

The CD4051B, CD4052B, and CD4053B analog multiplexers are digitally-controlled analog switches that have low ON impedance and very low OFF leakage current. Control of analog signals up to 20  $V_{P-P}$  can be achieved by digital signal amplitudes of 4.5 V to 20 V (If  $V_{DD} - V_{SS} = 3 V$ , a  $V_{DD} - V_{EE}$  of up to 13 V can be controlled; for  $V_{DD} - V_{EE}$  level differences above 13 V, a  $V_{DD} - V_{SS}$  of at least 4.5 V is required). For example, if  $V_{DD} = 4.5 V$ ,  $V_{SS} = 0 V$ , and  $V_{EE} = -13.5 V$ , analog signals from  $-13.5 V$  to 4.5 V can be controlled by digital inputs of 0 V to 5 V. These multiplexer circuits dissipate extremely low quiescent power over the full  $V_{DD} - V_{SS}$  and  $V_{DD} - V_{EE}$  supply-voltage ranges, independent of the logic state of the control signals. When a logic high (H) is present at the inhibit (INH) input, all channels are off.

## ORDERING INFORMATION†

TA	PACKAGE‡		ORDERABLE PART NUMBER	TOP-SIDE MARKING
-40°C to 125°C	SOIC – M	Reel of 2500	CD4051BQM96Q1	CD4051Q
	TSSOP – PW	Reel of 2000	CD4051BQPWRQ1	CM051BQ
	SOIC – M	Reel of 2500	CD4052BQM96Q1§	CD4052Q
	TSSOP – PW	Reel of 2000	CD4052BQPWRQ1§	CD4052Q
	SOIC – M	Reel of 2500	CD4053BQM96Q1	CD4053Q
	TSSOP – PW	Reel of 2000	CD4053BQPWRQ1§	CD4053Q

† For the most current package and ordering information, see the Package Option Addendum at the end of this document, or see the TI web site at <http://www.ti.com>.

‡ Package drawings, thermal data, and symbolization are available at <http://www.ti.com/packaging>.

§ Product Preview



Please be aware that an important notice concerning availability, standard warranty, and use in critical applications of Texas Instruments semiconductor products and disclaimers thereto appears at the end of this data sheet.

UNLESS OTHERWISE NOTED this document contains PRODUCTION DATA information current as of publication date. Products conform to specifications per the terms of Texas Instruments standard warranty. Production processing does not necessarily include testing of all parameters.

 **TEXAS  
INSTRUMENTS**

POST OFFICE BOX 655303 • DALLAS, TEXAS 75265

Copyright © 2008, Texas Instruments Incorporated

# CD4051B-Q1, CD4052B-Q1, CD4053B-Q1 CMOS ANALOG MULTIPLEXERS/DEMULTIPLEXERS WITH LOGIC-LEVEL CONVERSION

SCHS354A – AUGUST 2004 – REVISED JANUARY 2008

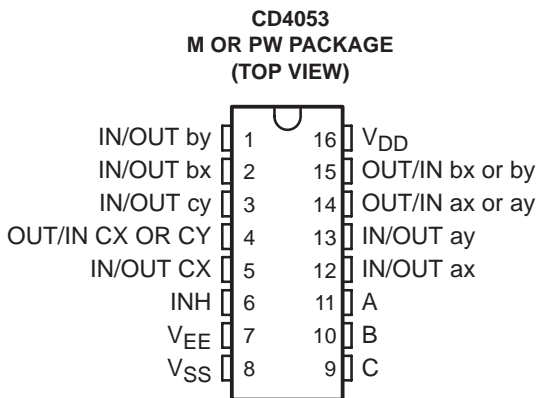
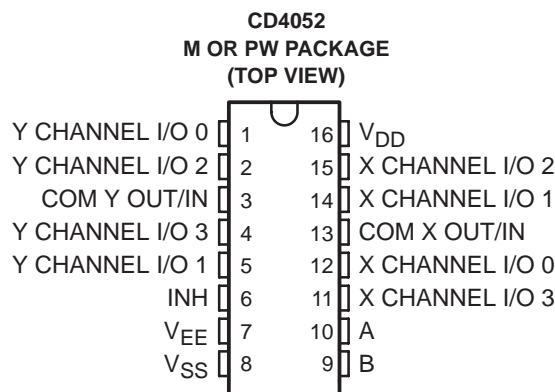
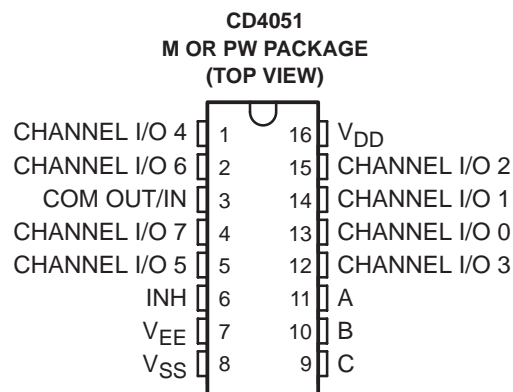
## description/ordering information (continued)

The CD4051B is a single eight-channel multiplexer that has three binary control inputs (A, B, and C) and an inhibit input. The three binary signals select one of eight channels to be turned on and connect one of the eight inputs to the output.

The CD4052B is a differential four-channel multiplexer that has two binary control inputs (A and B) and an inhibit input. The two binary input signals select one of four pairs of channels to be turned on and connect the analog inputs to the outputs.

The CD4053B is a triple two-channel multiplexer with three separate digital control inputs (A, B, and C) and an inhibit input. Each control input selects one of a pair of channels, which are connected in a single-pole, double-throw configuration.

When these devices are used as demultiplexers, the CHANNEL IN/OUT terminals are the outputs, and the common (COM OUT/IN) terminals are the inputs.



**CD4051B-Q1, CD4052B-Q1, CD4053B-Q1**  
**CMOS ANALOG MULTIPLEXERS/DEMULTIPLEXERS**  
**WITH LOGIC-LEVEL CONVERSION**

SCHS354A – AUGUST 2004 – REVISED JANUARY 2008

**Function Tables**

**CD4051**

INPUTS				ON CHANNEL
INH	C	B	A	
L	L	L	L	0
L	L	L	H	1
L	L	H	L	2
L	L	H	H	3
L	H	L	L	4
L	H	L	H	5
L	H	H	L	6
L	H	H	H	7
H	X	X	X	None

X = don't care

**CD4052**

INPUTS			ON CHANNEL
INH	B	A	
L	L	L	0x, 0y
L	L	H	1x, 2y
L	H	L	2x, 2y
L	H	H	3x, 3y
H	X	X	None

X = don't care

**CD4053**

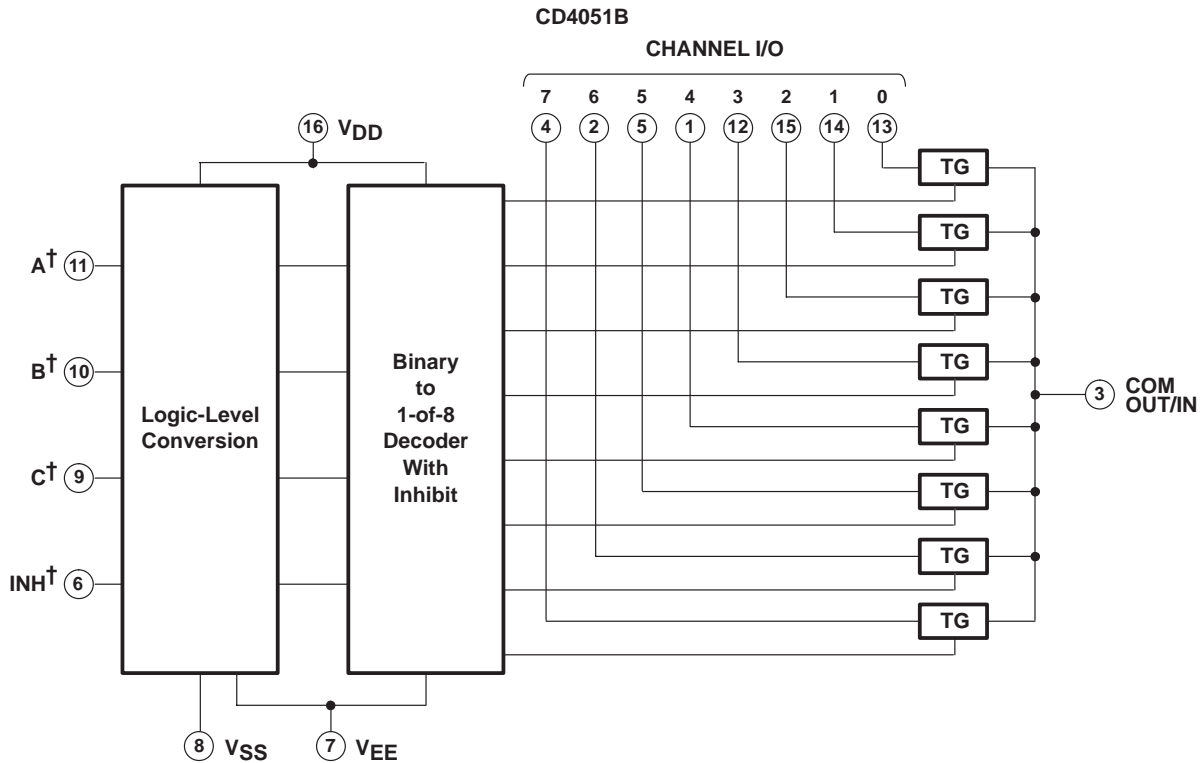
INPUTS		ON CHANNEL
INH	A OR B OR C	
L	L	ax or bx or cx
L	H	ay or by or cy
H	X	None

X = don't care

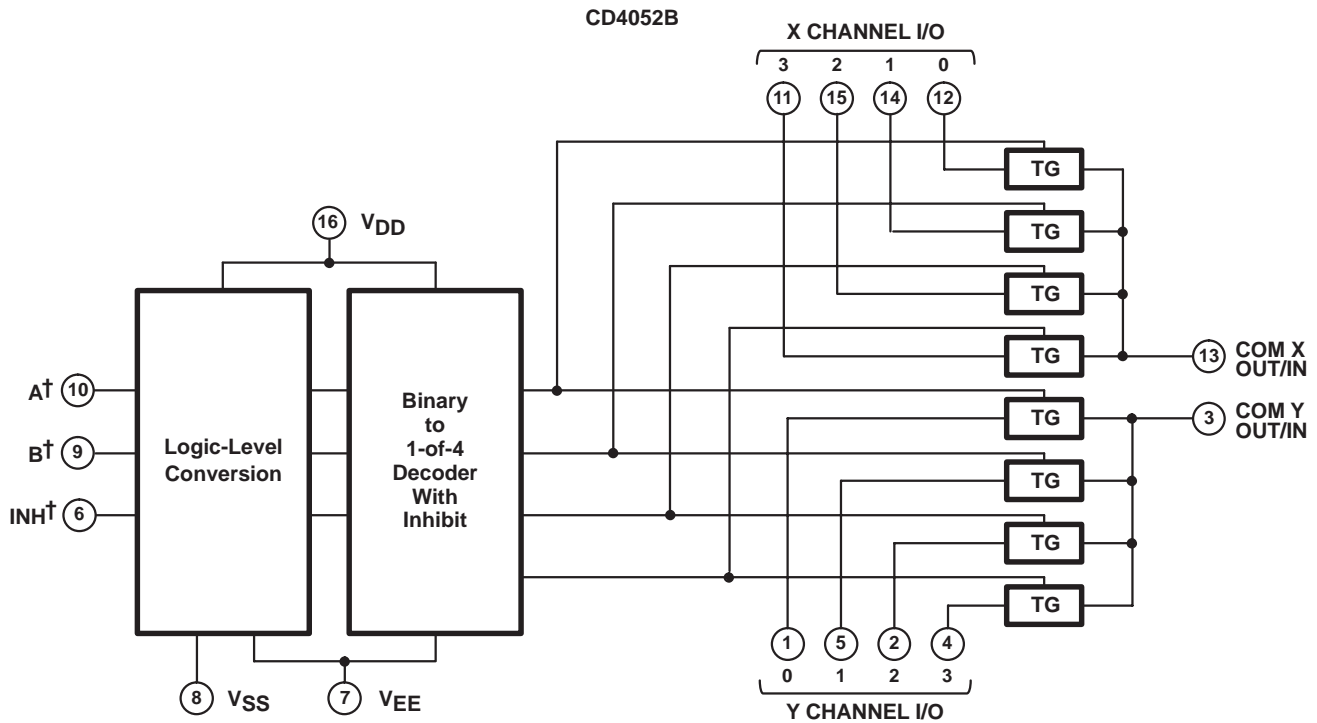
# CD4051B-Q1, CD4052B-Q1, CD4053B-Q1 CMOS ANALOG MULTIPLEXERS/DEMULTIPLEXERS WITH LOGIC-LEVEL CONVERSION

SCHS354A – AUGUST 2004 – REVISED JANUARY 2008

## logic diagram (positive logic)



† All inputs are protected by CMOS protection network.



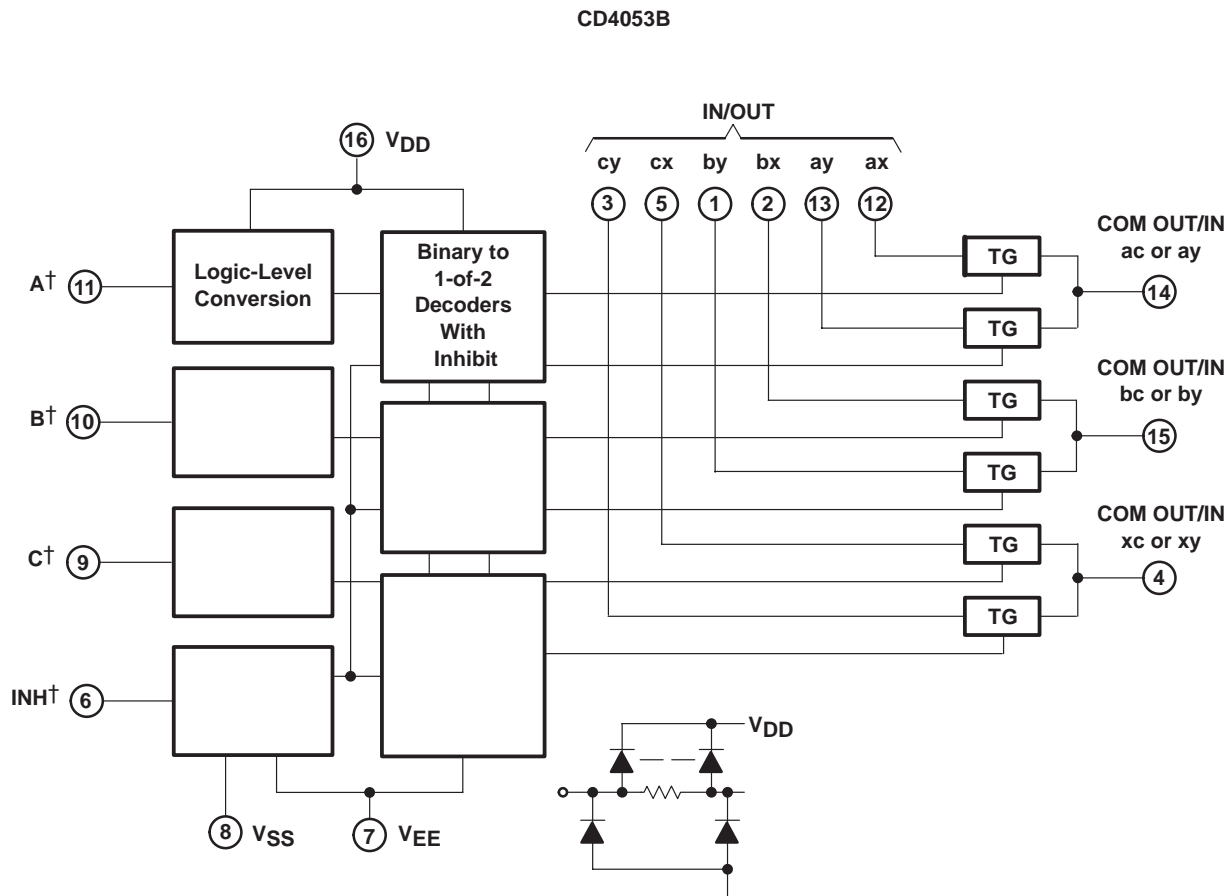
† All inputs are protected by CMOS protection network.



# CD4051B-Q1, CD4052B-Q1, CD4053B-Q1 CMOS ANALOG MULTIPLEXERS/DEMULTIPLEXERS WITH LOGIC-LEVEL CONVERSION

SCHS354A – AUGUST 2004 – REVISED JANUARY 2008

## logic diagrams (positive logic) (continued)



† All inputs are protected by standard CMOS protection network.

### absolute maximum ratings over operating free-air temperature (unless otherwise noted)‡

Supply voltage range, $V+$ to $V-$ (voltages referenced to $V_{SS}$ terminal)	-0.5 to 20 V
DC input voltage range	-0.5 V to $V_{DD} + 0.5$ V
DC input current, any one input	$\pm 10$ mA
Package thermal impedance, $\theta_{JA}$ (see Note 1): M package	73°C/W
PW package	108°C/W
Maximum junction temperature, $T_J$	150°C
Lead temperature (during soldering):	
At distance $1/16 \pm 1/32$ inch ( $1,59 \pm 0,79$ mm) from case for 10 s max	265°C
Storage temperature range, $T_{Stg}$	-65°C to 150°C

‡ Stresses beyond those listed under "absolute maximum ratings" may cause permanent damage to the device. These are stress ratings only, and functional operation of the device at these or any other conditions beyond those indicated under "recommended operating conditions" is not implied. Exposure to absolute-maximum-rated conditions for extended periods may affect device reliability.

NOTE 1: The package thermal impedance is calculated in accordance with JESD 51-7.

# CD4051B-Q1, CD4052B-Q1, CD4053B-Q1 CMOS ANALOG MULTIPLEXERS/DEMULTIPLEXERS WITH LOGIC-LEVEL CONVERSION

SCHS354A – AUGUST 2004 – REVISED JANUARY 2008

## recommended operating conditions

		MIN	MAX	UNIT
$V_{DD}$	Supply voltage	5	20	V
$T_A$	Operating free-air temperature	-40	125	°C

electrical characteristics,  $V_{SUPPLY} = \pm 5$  V,  $A_V = 1$  V,  $R_L = 100 \Omega$ , unless otherwise noted (see Note 2)

PARAMETER	TEST CONDITIONS	$V_{DD}$ (V)	LIMITS AT INDICATED TEMPERATURES				UNIT
			-40°C	125°C	25°C		
					MIN	TYP	
$I_{DD}$ Quiescent device current		5	5	150	0.04	5	$\mu$ A
		10	10	300	0.04	10	
		15	20	600	0.04	20	
		20	100	3000	0.08	100	
<b>Signal Input (<math>V_{IS}</math>) and Output (<math>V_{OS}</math>)</b>							
$r_{on}$ Drain-to-source ON-state resistance	$V_{EE} = 0$ V, $V_{SS} = 0$ V, $V_{IS} = 0$ to $V_{DD}$	5	850	1300	470	1050	$\Omega$
		10	330	550	180	400	
		15	210	320	125	240	
$\Delta r_{on}$ ON-state resistance difference between any two switches	$V_{EE} = 0$ V, $V_{SS} = 0$ V	5			15		$\Omega$
		10			10		
		15			5		
Input/output leakage current (switch off)	Any channel OFF (MAX) or all channels OFF (COM OUT/IN) (Max), $V_{EE} = 0$ V, $V_{SS} = 0$ V, See Note 3	18	$\pm 0.1$	$\pm 1$	$\pm 10^{-5}$	$\pm 0.1$	$\mu$ A
$C_{is}$ Input capacitance	$V_{EE} = -5$ V, $V_{SS} = -5$ V	5			5		pF
$C_{os}$ Output capacitance	$V_{EE} = -5$ V, $V_{SS} = -5$ V	CD4051			30		pF
		CD4052	5			18	
		CD4053				9	
$C_{ios}$ Feedthrough capacitance	$V_{EE} = -5$ V, $V_{SS} = -5$ V	5			0.2		pF
$t_{pd}$ Propagation delay (signal input to output)	$V_{IS(p-p)} = V_{DD}$ , $R_L = 200$ k $\Omega$ , $C_L = 50$ pF, $t_r, t_f = 20$ ns	5			30	60	ns
		10			15	30	
		15			10	20	

NOTES: 2. Peak-to-peak voltage symmetrical about  $\frac{V_{DD} - V_{EE}}{2}$

3. Determined by minimum feasible leakage measurement for automatic testing



**CD4051B-Q1, CD4052B-Q1, CD4053B-Q1**  
**CMOS ANALOG MULTIPLEXERS/DEMULTIPLEXERS**  
**WITH LOGIC-LEVEL CONVERSION**

SCHS354A – AUGUST 2004 – REVISED JANUARY 2008

electrical characteristics,  $V_{SUPPLY} = \pm 5\text{ V}$ ,  $A_V = 1\text{ V}$ ,  $R_L = 100\ \Omega$ , unless otherwise noted  
(see Note 2) (continued)

PARAMETER	TEST CONDITIONS	$V_{EE}$ (V)	$V_{DD}$ (V)	LIMITS AT INDICATED TEMPERATURES					UNIT
				-40°C	125°C	25°C			
						MIN	TYP	MAX	
<b>Control (Address or Inhibit), <math>V_C</math></b>									
$V_{IL}$ Input low voltage	$V_{IL} = V_{DD}$ through $1\text{ k}\Omega$ , $V_{IH} = V_{DD}$ through $1\text{ k}\Omega$ , $R_L = 1\text{ k}\Omega$ to $V_{SS}$ , $I_{IS} < 2\ \mu\text{A}$ on all OFF channels	$V_{SS}$	5	1.5	1.5	1.5		V	
		$V_{SS}$	10	3	3	3			
		$V_{SS}$	15	4	4	4			
$V_{IH}$ Input high voltage	$V_{IL} = V_{DD}$ through $1\text{ k}\Omega$ , $V_{IH} = V_{DD}$ through $1\text{ k}\Omega$ , $R_L = 1\text{ k}\Omega$ to $V_{SS}$ , $I_{IS} < 2\ \mu\text{A}$ on all OFF channels	$V_{SS}$	5	3.5	3.5	3.5		V	
		$V_{SS}$	10	7	7	7			
		$V_{SS}$	15	11	11	11			
$I_{IN}$ Input current	$V_{IN} = 0\text{ V}, 18\text{ V}$		18	$\pm 0.1$	$\pm 1$	$\pm 10^{-5}$	$\pm 0.1$	$\mu\text{A}$	
$t_{pd1}$ Address-to-signal OUT (channels ON or OFF) propagation delay	$t_r, t_f = 20\text{ ns}$ , $C_L = 50\text{ pF}$ , $R_L = 10\text{ k}\Omega$ , $V_{SS} = 0\text{ V}$ , See Figure 10, Figure 11, and Figure 14	0	5			450	720	ns	
		0	10			160	320		
		0	15			120	240		
		-5	5			225	450		
$t_{pd2}$ Inhibit-to-signal OUT (channel turning ON) propagation delay	$t_r, t_f = 20\text{ ns}$ , $C_L = 50\text{ pF}$ , $R_L = 1\text{ k}\Omega$ , $V_{SS} = 0\text{ V}$ , See Figure 11	0	5			400	720	ns	
		0	10			160	320		
		0	15			120	240		
		-10	5			200	400		
$t_{pd3}$ Inhibit-to-signal OUT (channel turning OFF) propagation delay	$t_r, t_f = 20\text{ ns}$ , $C_L = 50\text{ pF}$ , $R_L = 10\text{ k}\Omega$ , $V_{SS} = 0\text{ V}$ , See Figure 15	0	5			200	450	ns	
		0	10			90	210		
		0	15			70	160		
		-10	5			130	300		
$C_{IN}$ Input capacitance, any address or inhibit input						5	7.5	pF	

NOTES: 2: Peak-to-peak voltage symmetrical about  $\frac{V_{DD} - V_{EE}}{2}$

3: Determined by minimum feasible leakage measurement for automatic testing

# CD4051B-Q1, CD4052B-Q1, CD4053B-Q1 CMOS ANALOG MULTIPLEXERS/DEMULTIPLEXERS WITH LOGIC-LEVEL CONVERSION

SCHS354A – AUGUST 2004 – REVISED JANUARY 2008

## electrical specifications

PARAMETER	TEST CONDITIONS		V <sub>IS</sub> (V)	V <sub>DD</sub> (V)	LIMITS AT INDICATED TEMPERATURES			UNIT
					25°C			
					MIN	TYP	MAX	
-3-dB cutoff frequency, channel ON (sine-wave input)	R <sub>L</sub> = 1 kΩ, V <sub>OS</sub> at COM OUT/IN, See Note 2, V <sub>OS</sub> at COM OUT/IN	CD4053	5	10	30			MHz
		CD4052	5	10	25			
		CD4051	5	10	20			
	V <sub>EE</sub> = V <sub>SS</sub> , 20log V <sub>OS</sub> /V <sub>IS</sub> = -3 dB, V <sub>OS</sub> at any channel				60			
THD Total harmonic distortion	R <sub>L</sub> = 10 kΩ, See Note 2		2	5	0.3			%
			3	10	0.2			
			5	15	0.12			
	V <sub>EE</sub> = V <sub>SS</sub> , f <sub>IS</sub> = 1-kHz sine wave				0.12			
-40-dB feedthrough frequency (all channels OFF)	R <sub>L</sub> = 1 kΩ, V <sub>OS</sub> at COM OUT/IN, See Note 2	CD4053	5	10	8			MHz
		CD4052	5	10	10			
		CD4051	5	10	12			
	V <sub>EE</sub> = V <sub>SS</sub> , 20log V <sub>OS</sub> /V <sub>IS</sub> = -40 dB, V <sub>OS</sub> at any channel				8			
-40-dB signal crosstalk frequency	R <sub>L</sub> = 1 kΩ, between any two channels, See Note 2		5	10	3			MHz
	V <sub>EE</sub> = V <sub>SS</sub> , 20log V <sub>OS</sub> /V <sub>IS</sub> = -40 dB, Between sections, Measured on common	CD4052			6			
			V <sub>EE</sub> = V <sub>SS</sub> , 20log V <sub>OS</sub> /V <sub>IS</sub> = -40 dB, Between sections, Measured on any channel				10	
	V <sub>EE</sub> = V <sub>SS</sub> , 20log V <sub>OS</sub> /V <sub>IS</sub> = -40 dB, Between any two sections, In pin 2, Out pin 14	CD4053			2.5			
			V <sub>EE</sub> = V <sub>SS</sub> , 20log V <sub>OS</sub> /V <sub>IS</sub> = -40 dB, Between any two sections, In pin 15, Out pin 14				6	
Address or inhibit to signal crosstalk	R <sub>L</sub> = 10 kΩ, See Note 4			10	65			mVPEAK
	V <sub>EE</sub> = 0 V, V <sub>SS</sub> = 0 V, t <sub>r</sub> , t <sub>f</sub> = 20 ns, V <sub>CC</sub> = V <sub>DD</sub> - V <sub>SS</sub> (square wave)				65			

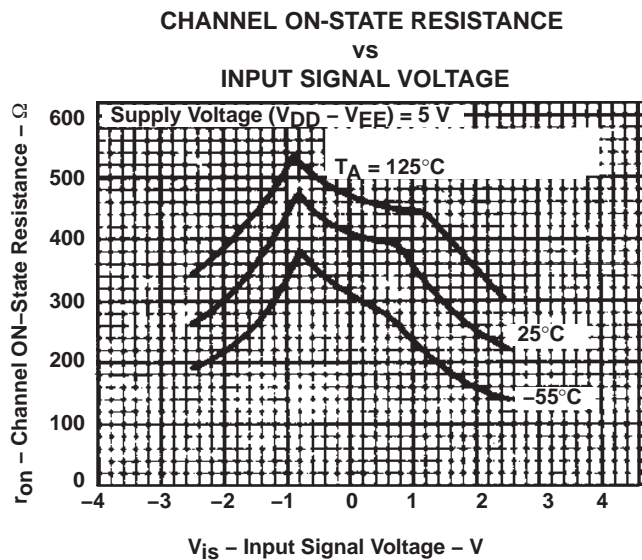
NOTES: 2. Peak-to-peak voltage symmetrical about  $\frac{V_{DD} - V_{EE}}{2}$

4. Both ends of channel



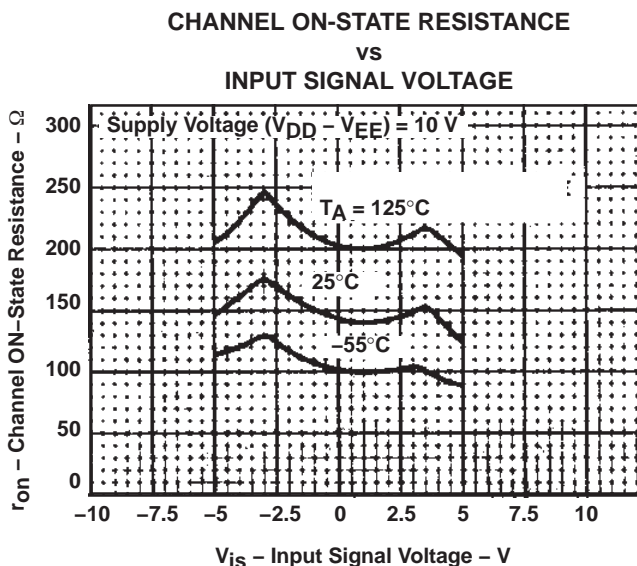


TYPICAL CHARACTERISTICS



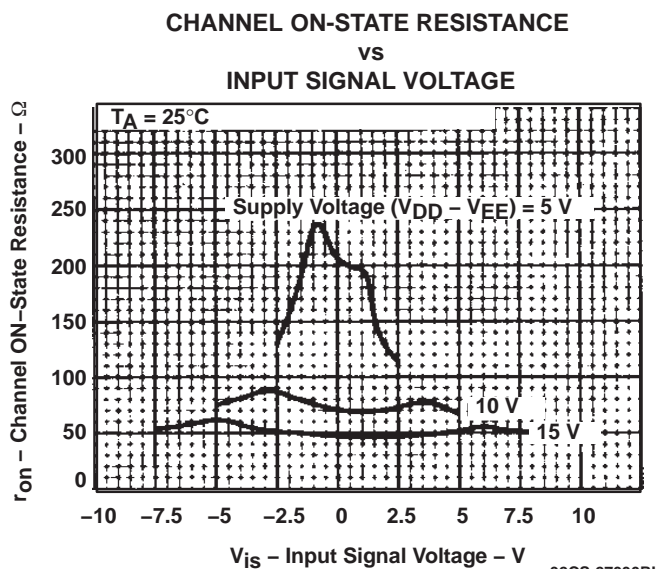
92CS-27326RI

Figure 1



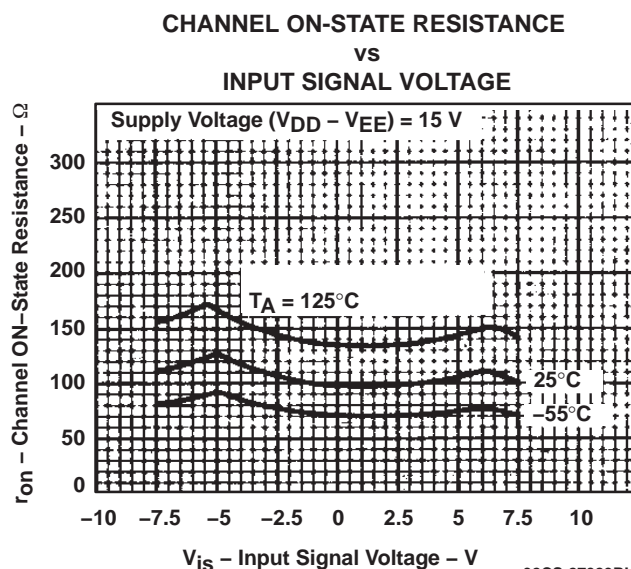
92CS-27327RI

Figure 2



92CS-27330RI

Figure 3



92CS-27329RI

Figure 4

# CD4051B-Q1, CD4052B-Q1, CD4053B-Q1 CMOS ANALOG MULTIPLEXERS/DEMULTIPLEXERS WITH LOGIC-LEVEL CONVERSION

SCHS354A – AUGUST 2004 – REVISED JANUARY 2008

## TYPICAL CHARACTERISTICS

ON CHARACTERISTICS FOR  
1-OF-8 CHANNELS (CD4051B)

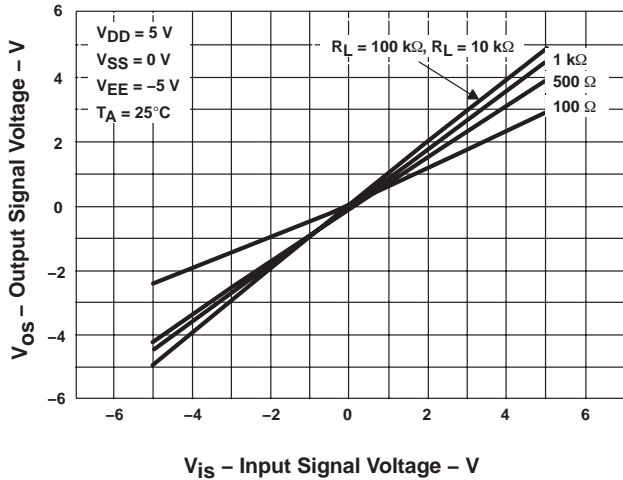


Figure 5

DYNAMIC POWER DISSIPATION  
VS  
SWITCHING FREQUENCY (CD4051B)

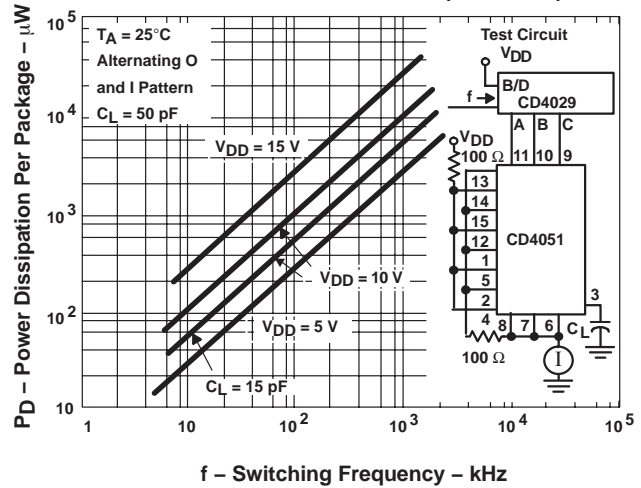


Figure 6

DYNAMIC POWER DISSIPATION  
VS  
SWITCHING FREQUENCY (CD4052B)

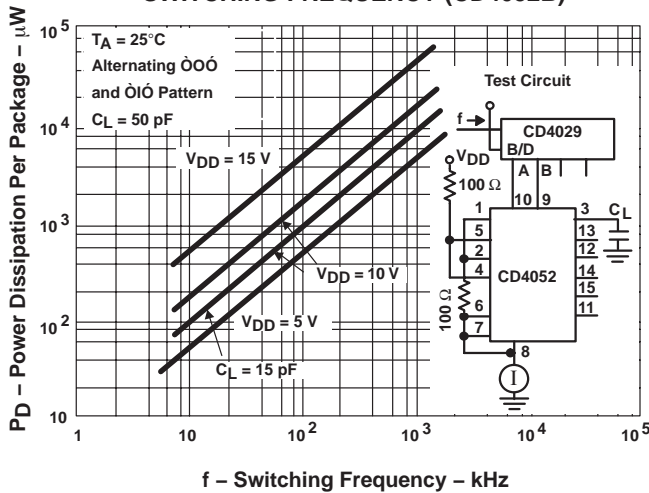


Figure 7

DYNAMIC POWER DISSIPATION  
VS  
SWITCHING FREQUENCY (CD4053B)

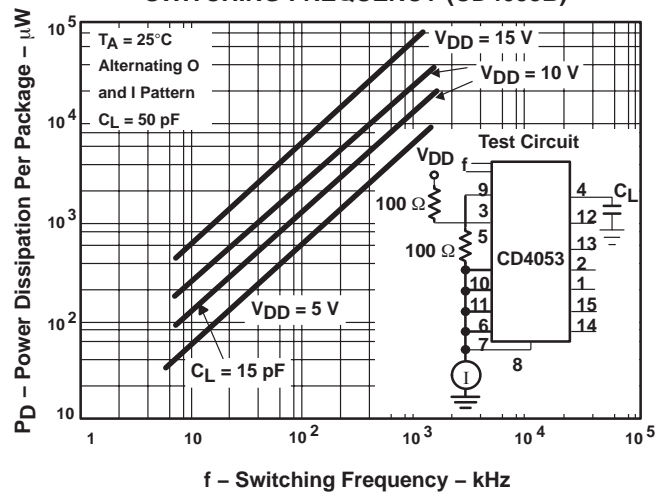
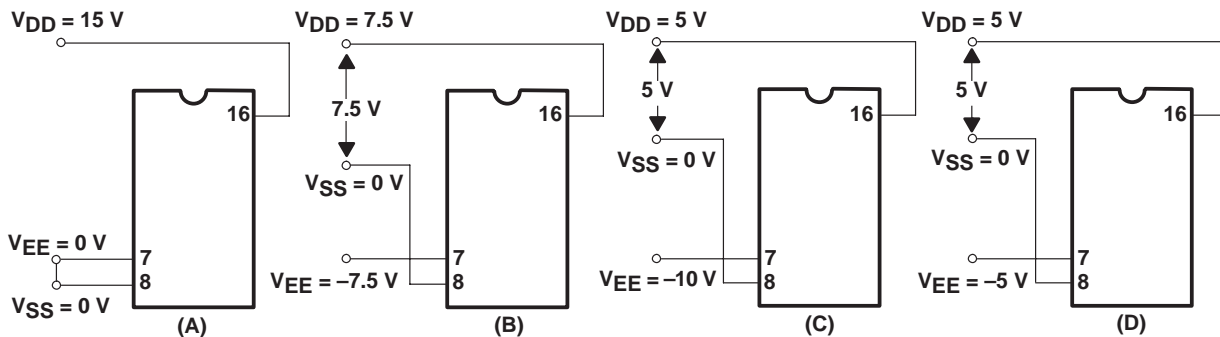


Figure 8

# CD4051B-Q1, CD4052B-Q1, CD4053B-Q1 CMOS ANALOG MULTIPLEXERS/DEMULTIPLEXERS WITH LOGIC-LEVEL CONVERSION

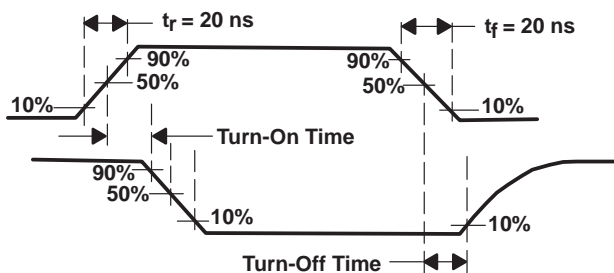
SCHS354A – AUGUST 2004 – REVISED JANUARY 2008

## PARAMETER MEASUREMENT INFORMATION

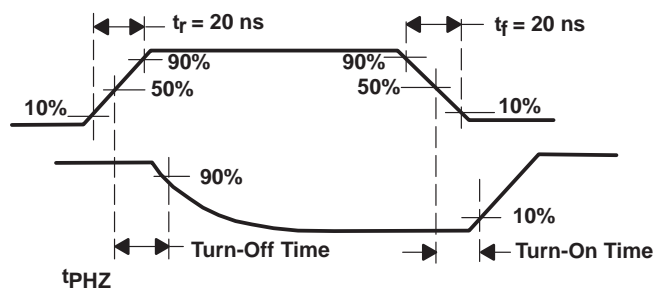


NOTE: The A, B, C, and INH input logic levels are L =  $V_{SS}$  and H =  $V_{DD}$ . The analog signal (through the TG) may swing from  $V_{EE}$  to  $V_{DD}$ .

**Figure 9. Typical Bias-Voltage Test Circuits**



**Figure 10. Channel Turned ON Waveforms**  
( $R_L = 1\text{ k}\Omega$ )

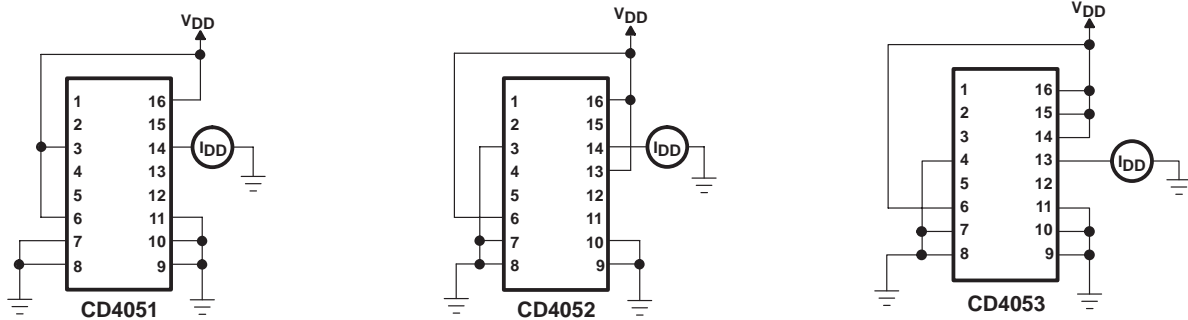


**Figure 11. Channel Turned OFF Waveforms**  
( $R_L = 1\text{ k}\Omega$ )

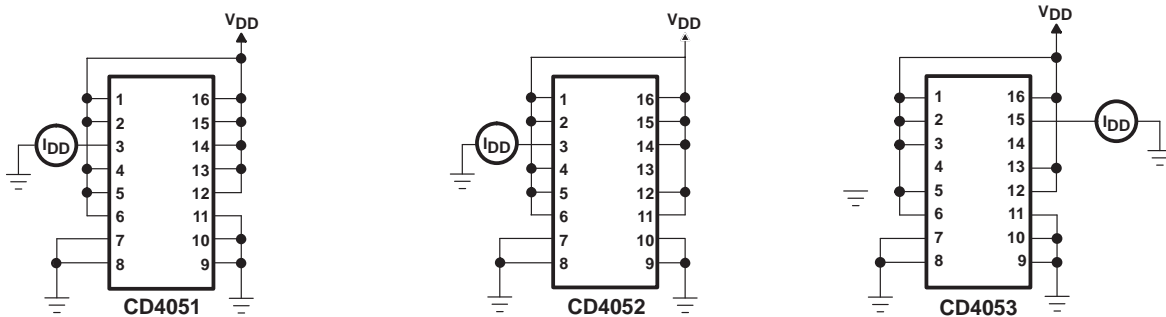
**CD4051B-Q1, CD4052B-Q1, CD4053B-Q1**  
**CMOS ANALOG MULTIPLEXERS/DEMULTIPLEXERS**  
**WITH LOGIC-LEVEL CONVERSION**

SCHS354A – AUGUST 2004 – REVISED JANUARY 2008

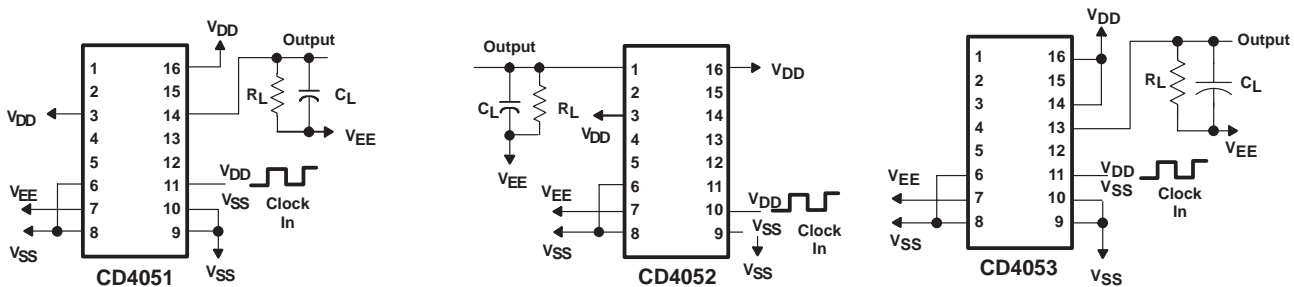
**PARAMETER MEASUREMENT INFORMATION**



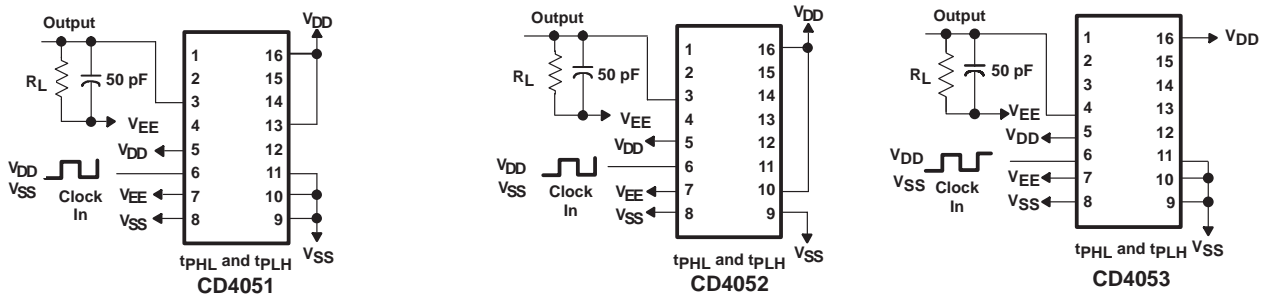
**Figure 12. OFF Channel Leakage Current, Any Channel OFF**



**Figure 13. OFF Channel Leakage Current, All Channels OFF**

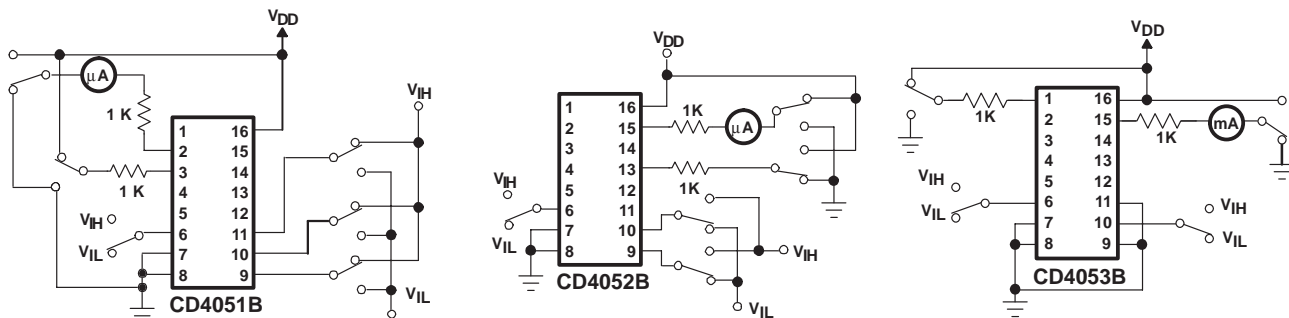


**Figure 14. Propagation Delay, Address Input to Signal Output**



**Figure 15. Propagation Delay, Inhibit Input to Signal Output**

**PARAMETER MEASUREMENT INFORMATION**

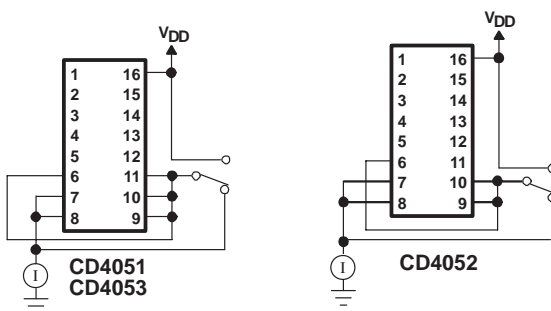


Measure <2 μA on All OFF Channels (e.g., Channel 6)

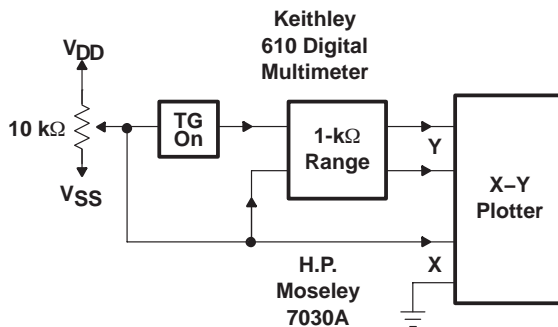
Measure <2 μA on All OFF Channels (e.g., Channel 2x)

Measure <2 μA on All OFF Channels (e.g., Channel by)

**Figure 16. Input-Voltage Test Circuit (Noise Immunity)**



**Figure 17. Quiescent Device Current**

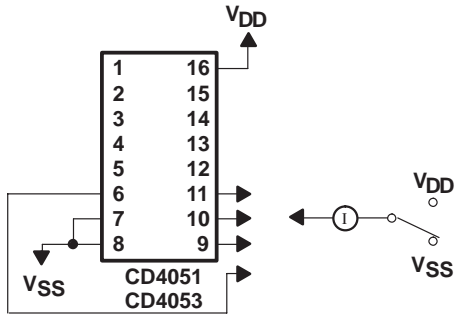


**Figure 18. Channel ON-Resistance Test Circuit**

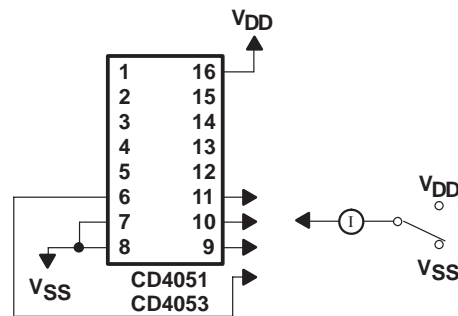
# CD4051B-Q1, CD4052B-Q1, CD4053B-Q1 CMOS ANALOG MULTIPLEXERS/DEMULTIPLEXERS WITH LOGIC-LEVEL CONVERSION

SCHS354A – AUGUST 2004 – REVISED JANUARY 2008

## PARAMETER MEASUREMENT INFORMATION



NOTE: Measure inputs sequentially to both  $V_{DD}$  and  $V_{SS}$ . Connect all unused inputs to either  $V_{DD}$  or  $V_{SS}$ .



NOTE: Measure inputs sequentially to both  $V_{DD}$  and  $V_{SS}$ . Connect all unused inputs to either  $V_{DD}$  or  $V_{SS}$ .

Figure 19. Input Current

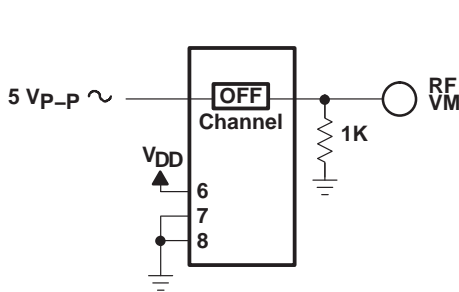


Figure 20. Feedthrough

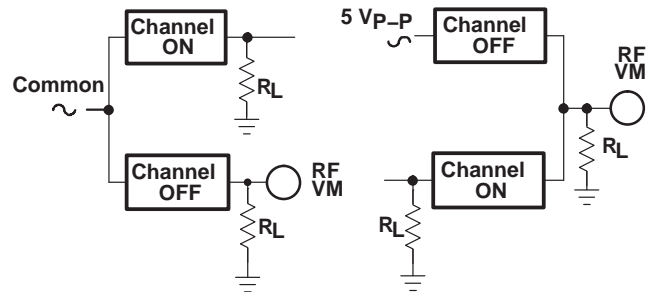


Figure 21. Crosstalk Between Any Two Channels

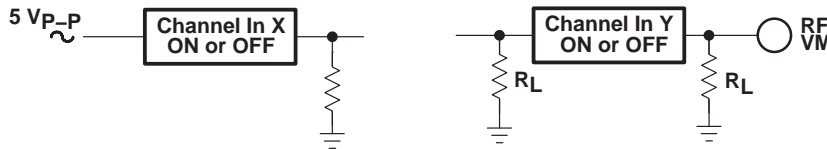


Figure 22. Crosstalk Between Duals or Triplets (CD4052B, CD4053B)

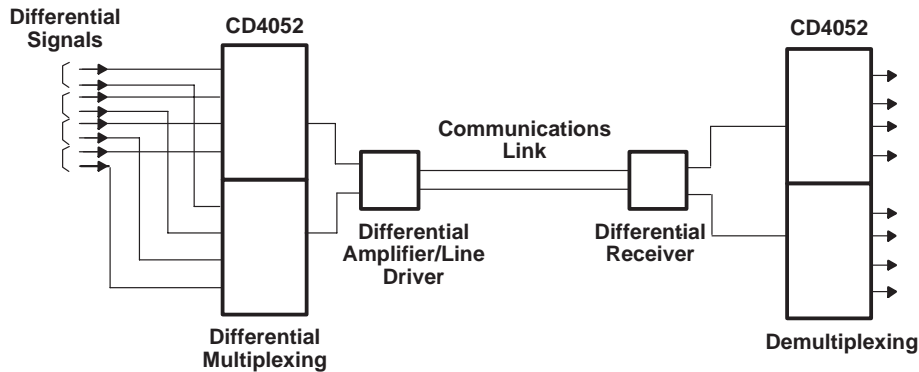


Figure 23. Typical Time-Division Application of the CD4052B

# CD4051B-Q1, CD4052B-Q1, CD4053B-Q1 CMOS ANALOG MULTIPLEXERS/DEMULTIPLEXERS WITH LOGIC-LEVEL CONVERSION

SCHS354A – AUGUST 2004 – REVISED JANUARY 2008

## APPLICATION INFORMATION

In applications where separate power sources drive  $V_{DD}$  and the signal inputs, the  $V_{DD}$  current capability should exceed  $V_{DD}/R_L$  ( $R_L$  = effective external load). This provision avoids permanent current flow or clamp action on the  $V_{DD}$  supply when power is applied or removed from the CD4051B, CD4052B, or CD4053B.

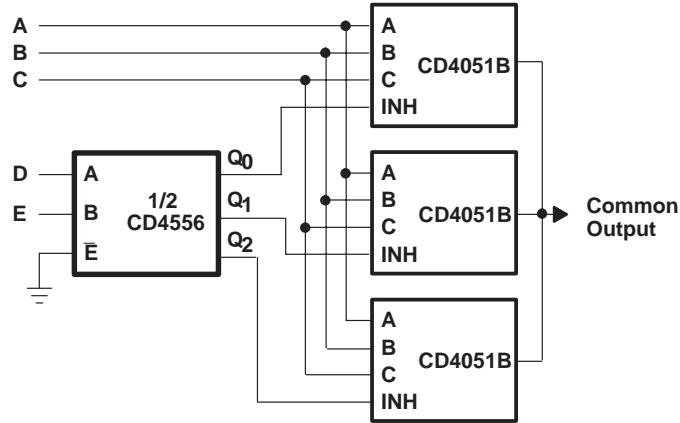


Figure 24. 24-to-1 Multiplexer Addressing

**PACKAGING INFORMATION**

Orderable Device	Status <sup>(1)</sup>	Package Type	Package Drawing	Pins	Package Qty	Eco Plan <sup>(2)</sup>	Lead/Ball Finish	MSL Peak Temp <sup>(3)</sup>
CD4051BQPWRQ1	ACTIVE	TSSOP	PW	16	2000	Pb-Free (RoHS)	CU NIPDAU	Level-1-250C-UNLIM
CD4053BQM96Q1	ACTIVE	SOIC	D	16	2500	Pb-Free (RoHS)	CU NIPDAU	Level-2-250C-1 YEAR/ Level-1-235C-UNLIM

<sup>(1)</sup> The marketing status values are defined as follows:

**ACTIVE:** Product device recommended for new designs.

**LIFEBUY:** TI has announced that the device will be discontinued, and a lifetime-buy period is in effect.

**NRND:** Not recommended for new designs. Device is in production to support existing customers, but TI does not recommend using this part in a new design.

**PREVIEW:** Device has been announced but is not in production. Samples may or may not be available.

**OBsolete:** TI has discontinued the production of the device.

<sup>(2)</sup> Eco Plan - The planned eco-friendly classification: Pb-Free (RoHS), Pb-Free (RoHS Exempt), or Green (RoHS & no Sb/Br) - please check <http://www.ti.com/productcontent> for the latest availability information and additional product content details.

**TBD:** The Pb-Free/Green conversion plan has not been defined.

**Pb-Free (RoHS):** TI's terms "Lead-Free" or "Pb-Free" mean semiconductor products that are compatible with the current RoHS requirements for all 6 substances, including the requirement that lead not exceed 0.1% by weight in homogeneous materials. Where designed to be soldered at high temperatures, TI Pb-Free products are suitable for use in specified lead-free processes.

**Pb-Free (RoHS Exempt):** This component has a RoHS exemption for either 1) lead-based flip-chip solder bumps used between the die and package, or 2) lead-based die adhesive used between the die and leadframe. The component is otherwise considered Pb-Free (RoHS compatible) as defined above.

**Green (RoHS & no Sb/Br):** TI defines "Green" to mean Pb-Free (RoHS compatible), and free of Bromine (Br) and Antimony (Sb) based flame retardants (Br or Sb do not exceed 0.1% by weight in homogeneous material)

<sup>(3)</sup> MSL, Peak Temp. -- The Moisture Sensitivity Level rating according to the JEDEC industry standard classifications, and peak solder temperature.

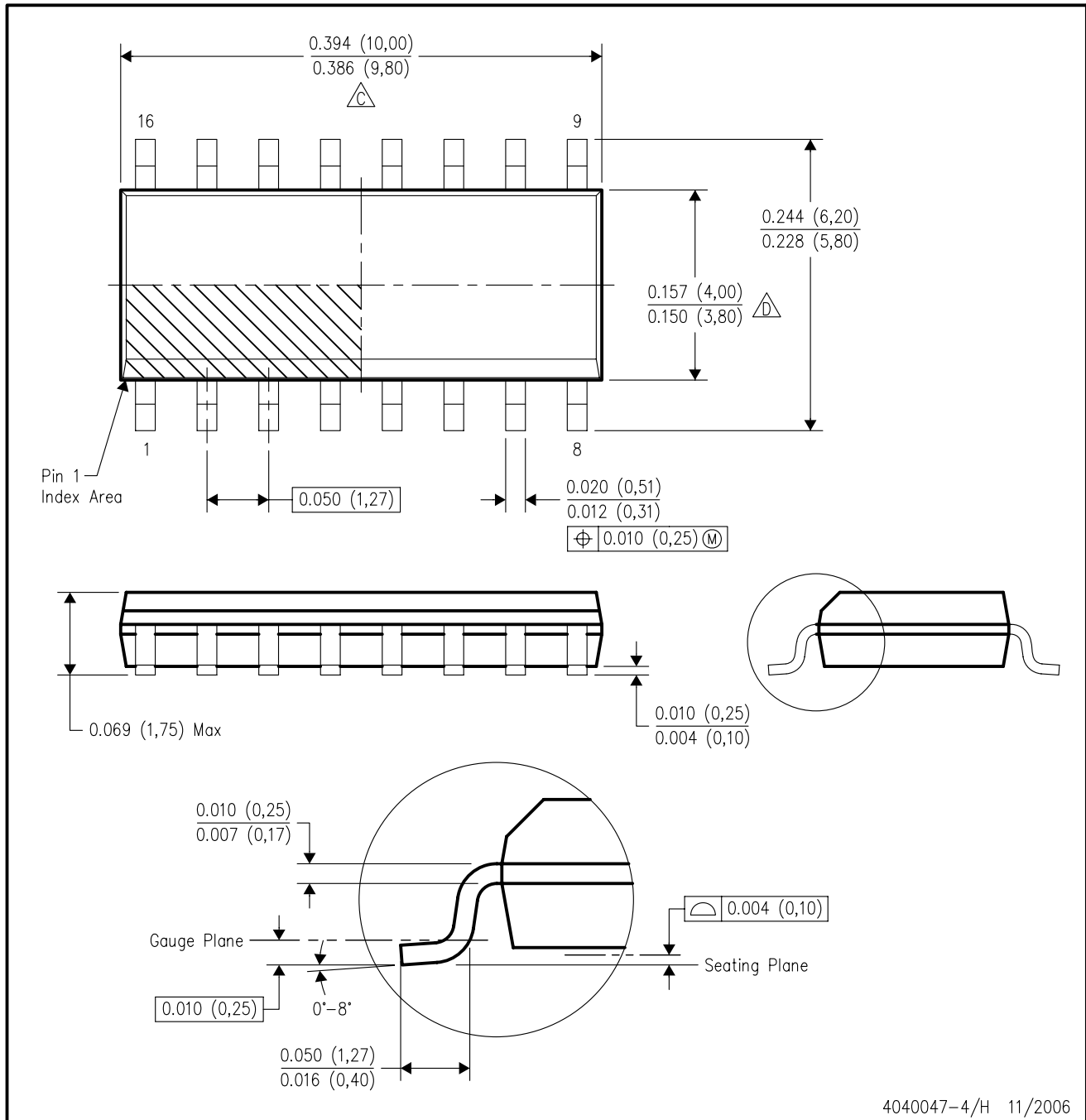
**Important Information and Disclaimer:**The information provided on this page represents TI's knowledge and belief as of the date that it is provided. TI bases its knowledge and belief on information provided by third parties, and makes no representation or warranty as to the accuracy of such information. Efforts are underway to better integrate information from third parties. TI has taken and continues to take reasonable steps to provide representative and accurate information but may not have conducted destructive testing or chemical analysis on incoming materials and chemicals. TI and TI suppliers consider certain information to be proprietary, and thus CAS numbers and other limited information may not be available for release.

In no event shall TI's liability arising out of such information exceed the total purchase price of the TI part(s) at issue in this document sold by TI to Customer on an annual basis.



D (R-PDSO-G16)

PLASTIC SMALL-OUTLINE PACKAGE



- NOTES:
- A. All linear dimensions are in inches (millimeters).
  - B. This drawing is subject to change without notice.
  - C. Body length does not include mold flash, protrusions, or gate burrs. Mold flash, protrusions, or gate burrs shall not exceed .006 (0,15) per end.
  - D. Body width does not include interlead flash. Interlead flash shall not exceed .017 (0,43) per side.
  - E. Reference JEDEC MS-012 variation AC.

PW (R-PDSO-G\*\*)

PLASTIC SMALL-OUTLINE PACKAGE

14 PINS SHOWN



4040064/F 01/97

- NOTES: A. All linear dimensions are in millimeters.  
 B. This drawing is subject to change without notice.  
 C. Body dimensions do not include mold flash or protrusion not to exceed 0,15.  
 D. Falls within JEDEC MO-153

## IMPORTANT NOTICE

Texas Instruments Incorporated and its subsidiaries (TI) reserve the right to make corrections, modifications, enhancements, improvements, and other changes to its products and services at any time and to discontinue any product or service without notice. Customers should obtain the latest relevant information before placing orders and should verify that such information is current and complete. All products are sold subject to TI's terms and conditions of sale supplied at the time of order acknowledgment.

TI warrants performance of its hardware products to the specifications applicable at the time of sale in accordance with TI's standard warranty. Testing and other quality control techniques are used to the extent TI deems necessary to support this warranty. Except where mandated by government requirements, testing of all parameters of each product is not necessarily performed.

TI assumes no liability for applications assistance or customer product design. Customers are responsible for their products and applications using TI components. To minimize the risks associated with customer products and applications, customers should provide adequate design and operating safeguards.

TI does not warrant or represent that any license, either express or implied, is granted under any TI patent right, copyright, mask work right, or other TI intellectual property right relating to any combination, machine, or process in which TI products or services are used. Information published by TI regarding third-party products or services does not constitute a license from TI to use such products or services or a warranty or endorsement thereof. Use of such information may require a license from a third party under the patents or other intellectual property of the third party, or a license from TI under the patents or other intellectual property of TI.

Reproduction of TI information in TI data books or data sheets is permissible only if reproduction is without alteration and is accompanied by all associated warranties, conditions, limitations, and notices. Reproduction of this information with alteration is an unfair and deceptive business practice. TI is not responsible or liable for such altered documentation. Information of third parties may be subject to additional restrictions.

Resale of TI products or services with statements different from or beyond the parameters stated by TI for that product or service voids all express and any implied warranties for the associated TI product or service and is an unfair and deceptive business practice. TI is not responsible or liable for any such statements.

TI products are not authorized for use in safety-critical applications (such as life support) where a failure of the TI product would reasonably be expected to cause severe personal injury or death, unless officers of the parties have executed an agreement specifically governing such use. Buyers represent that they have all necessary expertise in the safety and regulatory ramifications of their applications, and acknowledge and agree that they are solely responsible for all legal, regulatory and safety-related requirements concerning their products and any use of TI products in such safety-critical applications, notwithstanding any applications-related information or support that may be provided by TI. Further, Buyers must fully indemnify TI and its representatives against any damages arising out of the use of TI products in such safety-critical applications.

TI products are neither designed nor intended for use in military/aerospace applications or environments unless the TI products are specifically designated by TI as military-grade or "enhanced plastic." Only products designated by TI as military-grade meet military specifications. Buyers acknowledge and agree that any such use of TI products which TI has not designated as military-grade is solely at the Buyer's risk, and that they are solely responsible for compliance with all legal and regulatory requirements in connection with such use.

TI products are neither designed nor intended for use in automotive applications or environments unless the specific TI products are designated by TI as compliant with ISO/TS 16949 requirements. Buyers acknowledge and agree that, if they use any non-designated products in automotive applications, TI will not be responsible for any failure to meet such requirements.

Following are URLs where you can obtain information on other Texas Instruments products and application solutions:

### Products

Amplifiers	<a href="http://amplifier.ti.com">amplifier.ti.com</a>
Data Converters	<a href="http://dataconverter.ti.com">dataconverter.ti.com</a>
DSP	<a href="http://dsp.ti.com">dsp.ti.com</a>
Clocks and Timers	<a href="http://www.ti.com/clocks">www.ti.com/clocks</a>
Interface	<a href="http://interface.ti.com">interface.ti.com</a>
Logic	<a href="http://logic.ti.com">logic.ti.com</a>
Power Mgmt	<a href="http://power.ti.com">power.ti.com</a>
Microcontrollers	<a href="http://microcontroller.ti.com">microcontroller.ti.com</a>
RFID	<a href="http://www.ti-rfid.com">www.ti-rfid.com</a>
RF/IF and ZigBee® Solutions	<a href="http://www.ti.com/lprf">www.ti.com/lprf</a>

### Applications

Audio	<a href="http://www.ti.com/audio">www.ti.com/audio</a>
Automotive	<a href="http://www.ti.com/automotive">www.ti.com/automotive</a>
Broadband	<a href="http://www.ti.com/broadband">www.ti.com/broadband</a>
Digital Control	<a href="http://www.ti.com/digitalcontrol">www.ti.com/digitalcontrol</a>
Medical	<a href="http://www.ti.com/medical">www.ti.com/medical</a>
Military	<a href="http://www.ti.com/military">www.ti.com/military</a>
Optical Networking	<a href="http://www.ti.com/opticalnetwork">www.ti.com/opticalnetwork</a>
Security	<a href="http://www.ti.com/security">www.ti.com/security</a>
Telephony	<a href="http://www.ti.com/telephony">www.ti.com/telephony</a>
Video & Imaging	<a href="http://www.ti.com/video">www.ti.com/video</a>
Wireless	<a href="http://www.ti.com/wireless">www.ti.com/wireless</a>

Mailing Address: Texas Instruments, Post Office Box 655303, Dallas, Texas 75265  
Copyright 2008, Texas Instruments Incorporated